

Standard-Verschraubungen Typ 100

Standard fittings Type 100

Raccordi standard Tipo 100

Raccords standard Type 100



Material: Messing vernickelt
Gewinde: konisch und zylindrisch nach DIN 3852 Teil 1 und Teil 2
Größen: M5-G1"
Medium: Luft, Wasser, Öl, Dampf usw.
Temperatur: max. 150 °C
max.Druck: 60bar

Material: brass nickel plated
Threads: taper and parallel according to DIN 3852 Part 1 and Part 2
Sizes: M5-G1"
Media: air, water, oil, steam etc.
Temperature: max. 150 °C
max.Pressure: 60bar

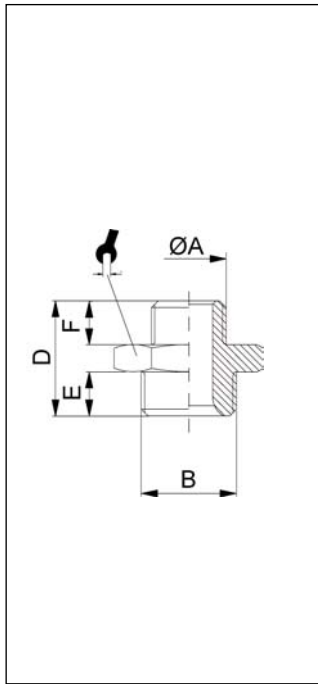

101

Doppelnippel zylindrisch

Parallel nipple, double

Nipplo cilindrico, doppio

Mamelon cylindrique, double

	A	B	D	E	F		
20101	M5	M5	11,5	4,0	4,0	8	100
20302	M5	G ¹ / ₈	14,5	6,0	4,0	14	100
20102	G ¹ / ₈	G ¹ / ₈	16,5	6,0	6,0	14	100
20303	G ¹ / ₈	G ¹ / ₄	19,0	8,0	6,0	17	100
20304	G ¹ / ₈	G ³ / ₈	20,0	9,0	6,0	19	100
20103	G ¹ / ₄	G ¹ / ₄	21,0	8,0	8,0	17	100
20305	G ¹ / ₄	G ³ / ₈	22,0	9,0	8,0	19	100
20306	G ¹ / ₄	G ¹ / ₂	23,5	10,0	8,0	24	100
20104	G ³ / ₈	G ³ / ₈	23,5	9,0	9,0	19	100
20307	G ³ / ₈	G ¹ / ₂	24,5	10,0	9,0	24	50
20105	G ¹ / ₂	G ¹ / ₂	25,5	10,0	10,0	24	50

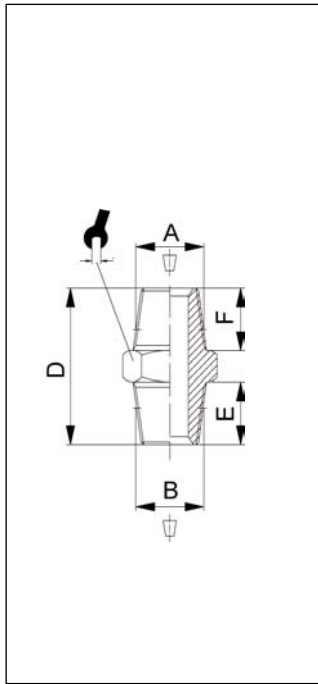

102

Doppelnippel konisch

Taper nipple, double

Nipplo conico, doppio

Mamelon conique, double

	A	B	D	E	F		
20101	M5	M5	11,5	4,0	4,0	8	100
20302	M5	G ¹ / ₈	14,5	6,0	4,0	14	100
20102	G ¹ / ₈	G ¹ / ₈	16,5	6,0	6,0	14	100
20303	G ¹ / ₈	G ¹ / ₄	19,0	8,0	6,0	17	100
20304	G ¹ / ₈	G ³ / ₈	20,0	9,0	6,0	19	100
20103	G ¹ / ₄	G ¹ / ₄	21,0	8,0	8,0	17	100
20305	G ¹ / ₄	G ³ / ₈	22,0	9,0	8,0	19	100
20306	G ¹ / ₄	G ¹ / ₂	23,5	10,0	8,0	24	100
20104	G ³ / ₈	G ³ / ₈	23,5	9,0	9,0	19	100
20307	G ³ / ₈	G ¹ / ₂	24,5	10,0	9,0	24	50
20105	G ¹ / ₂	G ¹ / ₂	25,5	10,0	10,0	24	50

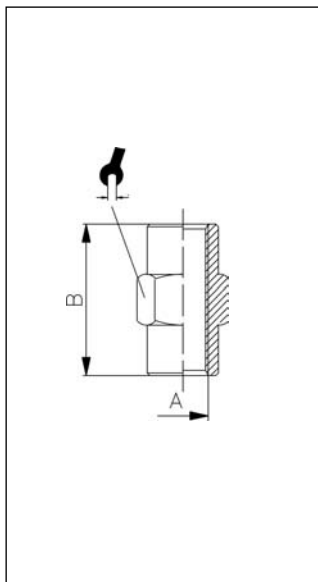

103

Muffe

Sleeve

Manicotto filettato

Manchon égal

	A	B		
30001	M5	11	8	100
30002	G ¹ / ₈	15	14	100
30003	G ¹ / ₄	22	17	100
30004	G ³ / ₈	23	22	100
30005	G ¹ / ₂	28	26	50
30006	G ³ / ₄	31	32	50

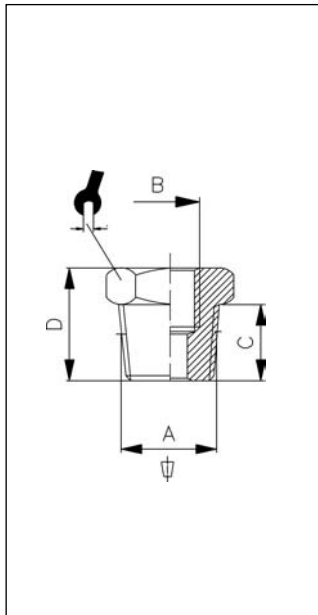

104

Reduzierung konisch

Taper reducer

Riduzione M/F conica

Réduction conique M/F

	A	B	C	D		
20801	R ¹ / ₄	G ¹ / ₈	11,0	16,0	14	100
20802	R ³ / ₈	G ¹ / ₈	11,5	16,5	17	100
20803	R ¹ / ₂	G ¹ / ₈	14,0	19,5	22	50
20804	R ³ / ₈	G ¹ / ₄	11,5	16,5	17	100
20805	R ¹ / ₂	G ¹ / ₄	14,0	19,5	22	50
20806	R ¹ / ₂	G ³ / ₈	14,0	19,5	22	50
20807	R ³ / ₄	G ¹ / ₂	16,5	23,0	27	50
20808	R1	G ¹ / ₂	19,0	26,5	34	25
20809	R1	G ³ / ₄	19,0	26,5	34	25
20810	R ¹ / ₄	G ³ / ₈	16,5	23,5	27	25

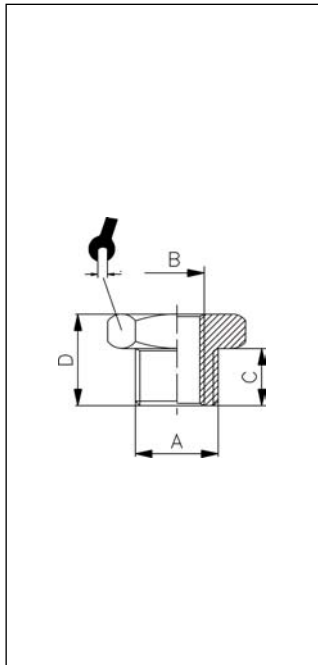

104/Z

Reduzierung zylindrisch

Parallel reducer

Riduzione M/F cilindrica

Réduction cylindrique M/F

	A	B	C	D		
20902	G ¹ / ₈	M5	6,0	10,5	14	100
20903	G ¹ / ₄	G ¹ / ₈	8,0	13,0	17	100
20904	G ³ / ₈	G ¹ / ₈	9,0	14,0	19	100
20905	G ³ / ₈	G ¹ / ₄	9,0	14,0	19	100
20906	G ¹ / ₂	G ¹ / ₈	10,0	15,5	24	100
20907	G ¹ / ₂	G ¹ / ₄	10,0	15,5	24	50
20908	G ¹ / ₂	G ³ / ₈	10,0	15,5	24	50
20909	G ³ / ₄	G ³ / ₈	12,0	17,5	30	50
20910	G ³ / ₄	G ¹ / ₂	12,0	17,5	30	50

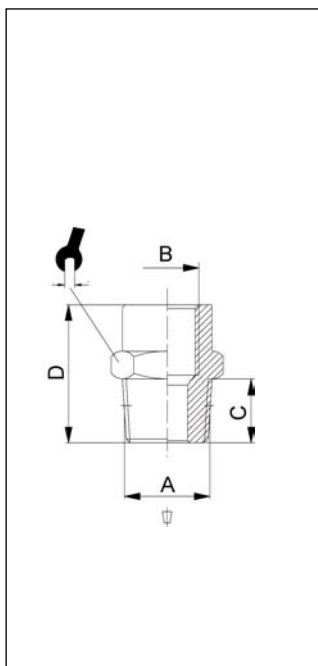

105

Verlängerung konisch

Taper M/F extension

Prolunga M/F conica

Prolongateur conique M/F

	A	B	C	D		
20402	R ¹ / ₈	G ¹ / ₈	8,0	18,0	14	100
20403	R ¹ / ₈	G ¹ / ₄	8,0	21,5	17	100
20404	R ¹ / ₈	G ³ / ₈	8,0	22,5	22	100
20405	R ¹ / ₄	G ¹ / ₄	11,0	24,5	17	100
20406	R ¹ / ₄	G ³ / ₈	11,0	25,5	22	100
20407	R ¹ / ₄	G ¹ / ₂	11,0	29,0	26	50
20408	R ³ / ₈	G ³ / ₈	11,5	26,0	22	100
20409	R ³ / ₈	G ¹ / ₂	11,5	29,5	26	50
20410	R ¹ / ₂	G ¹ / ₂	14,0	32,0	26	50
20411	R ¹ / ₂	G ³ / ₄	14,0	35,0	32	50

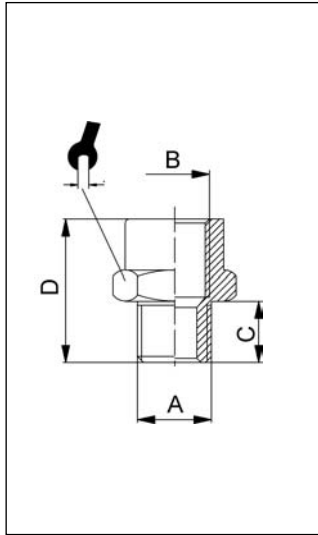

105/Z

Verlängerung zylindrisch

Parallel M/F extension

Prolunga M/F cilindrica

Prolongateur cylindrique M/F

	A	B	C	D		
20501	M5	G ¹ / ₈	4	14,0	14	100
20502	G ¹ / ₈	G ¹ / ₈	6	16,0	14	100
20503	G ¹ / ₈	G ¹ / ₄	6	20,0	17	100
20504	G ¹ / ₈	G ³ / ₈	6	20,5	22	100
20505	G ¹ / ₄	G ¹ / ₄	8	22,0	17	100
20506	G ¹ / ₄	G ³ / ₈	8	22,5	22	50
20507	G ¹ / ₄	G ¹ / ₂	8	26,0	26	100
20508	G ³ / ₈	G ³ / ₈	9	23,5	22	100
20509	G ³ / ₈	G ¹ / ₂	9	27,0	26	50
20510	G ¹ / ₂	G ¹ / ₂	10	28,0	26	50
20511	G ¹ / ₂	G ³ / ₄	12	38,0	32	25
20513	G ³ / ₄	G1	11	28,0	38	10

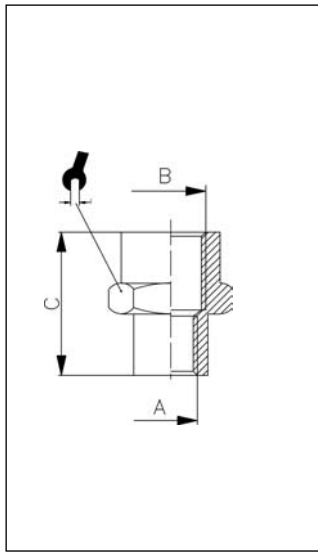

106

Verlängerung reduziert Innen-Innen

Reducing sleeve

Manicotto riduzione

Manchon inégal

	A	B	C		
30101	M5	G ¹ / ₈	13,5	14	100
30102	G ¹ / ₈	G ¹ / ₄	19,0	17	100
30103	G ¹ / ₈	G ³ / ₈	20,0	22	50
30104	G ¹ / ₈	G ¹ / ₂	23,5	24	100
30105	G ¹ / ₄	G ³ / ₈	22,5	22	50
30106	G ¹ / ₄	G ¹ / ₂	25,5	24	50
30107	G ³ / ₈	G ¹ / ₂	26,0	24	50
30108	G ¹ / ₂	G1	39,0	40	25
30109	G ³ / ₄	G1	39,0	40	25
30110	G ³ / ₄	G ¹ / ₂	30,0	30	25

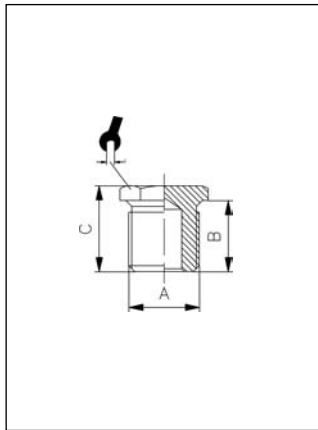

107

Stopfen

Parallel male plug

Tappo maschio

Bouchon Mâle cylindrique

	A	B	C			
30201	M5	4	7,5	-	8	100
30202	G ¹ / ₈	6,5	10,5	-	14	100
30203	G ¹ / ₄	8	13,0	-	17	100
30204	G ³ / ₈	9	14,0	-	19	100
30205	G ¹ / ₂	10	15,5	-	24	50
30206	G ³ / ₄	11	15,5	14	30	25
30207	G1	12	17,0	16	40	25

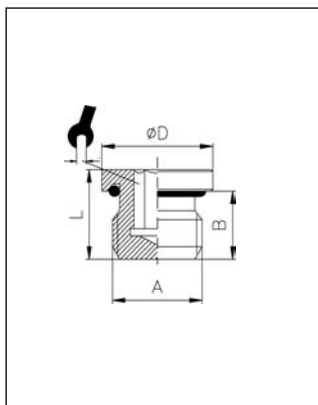

107 - OR

Stopfen mit O-Ring

Parallel male plug with O-ring

Tappo maschio con O-ring

Bouchon mâle cylindrique avec O ring

	A	B	L	ØD		
30150	M5	4,6	7,5	8,0	2,5	50
30151	M7	6,0	9,0	11,0	4	50
30152	G ¹ / ₈	6,5	9,5	14,0	5	50
30153	G ¹ / ₄	8,0	12,0	17,0	6	50
30154	G ³ / ₈	9,0	12,5	20,0	8	25
30155	G ¹ / ₂	11,0	14,0	26,0	10	25

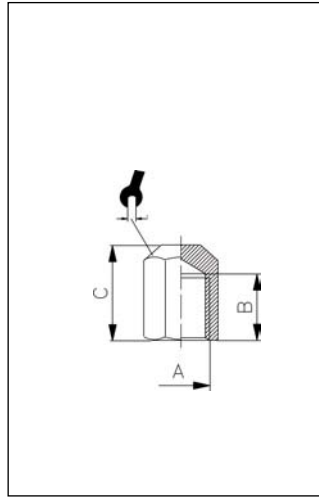

108

Kappe

Female plug

Tappo femmina

Bouchon femelle

	A	B	C		
30302	G ¹ / ₈	8,0	12,0	14	100
30303	G ¹ / ₄	11,0	15,5	17	100
30304	G ³ / ₈	11,5	17,0	20	50
30305	G ¹ / ₂	14,0	21,0	24	50

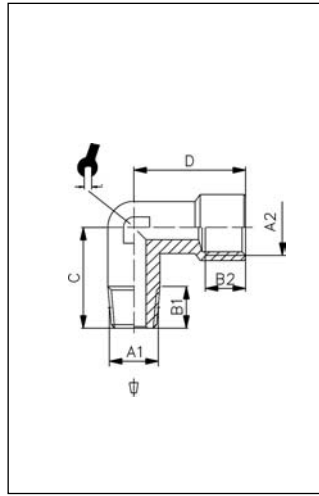

109

Winkelstück

Female elbow

Elle F.F

Équerre femelle femelle

	A	B	C		
50102	G ¹ / ₈	8,0	21,0	10	100
50103	G ¹ / ₄	11,0	25,5	13	50
50104	G ³ / ₈	11,5	28,0	17	25
50105	G ¹ / ₂	14,0	33,5	21	25
50106	G ³ / ₄	16,5	36,5	25	25
50107	G1	19,0	45,0	30	25

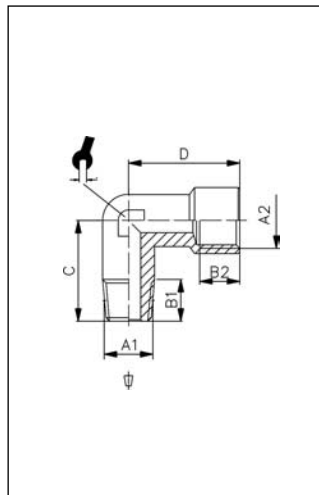

110

Winkelstück

Male-female elbow

L M/F

Équerre conique M/F

	A1	A2	B1	B2	C	D		
50201	M5	M5	4	4	11,5	11,0	9	100
50208	R ¹ / ₄	G ¹ / ₈	11,0	8,0	21,5	21,0	10	100
50202	R ¹ / ₈	G ¹ / ₈	8,0	8,0	18,5	21,0	10	100
50203	R ¹ / ₄	G ¹ / ₄	11,0	11,0	23,5	25,5	13	50
50204	R ¹ / ₄	G ¹ / ₄	11,5	11,5	26,0	28,0	17	25
50205	R ¹ / ₂	G ¹ / ₂	14,0	14,0	31,0	33,5	21	25
50206	R ³ / ₄	G ³ / ₄	16,0	16,5	33,0	36,5	25	10
50207	R1	G ³ / ₈	19,0	19,0	39,0	45,0	30	10

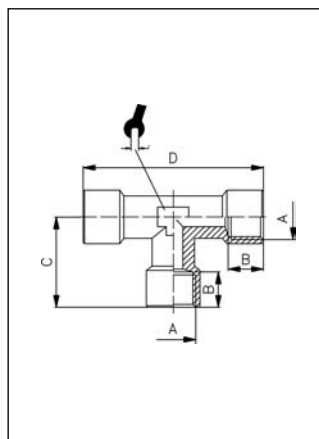

111

T-Stück

Female Tee

T.-F.F.F.

Té égal F.F.F.

	A	B	C	D		
40003	G ¹ / ₈	8,0	21,0	42,0	10	100
40004	G ¹ / ₄	11,0	25,5	51,0	13	50
40005	G ³ / ₈	11,5	28,0	56,0	17	25
40006	G ¹ / ₂	14,0	33,5	67,0	21	25
40007	G ³ / ₄	16,5	36,5	73,0	25	10
40008	G1	19,0	45,0	90,0	30	10

Ø

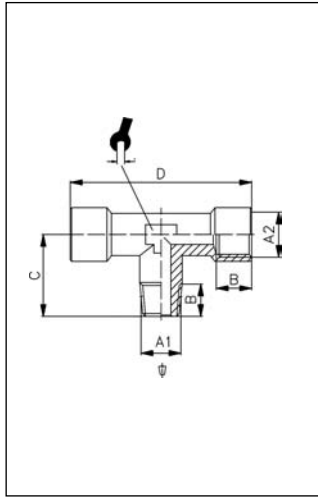

112

T-Stück konisch

Centre male Tee

T-F. M.F.

Té conique inégal F.F.M.

	A1	A2	B	C	D		
40401	M5	M5	4,0	11,5	22,0	9	100
40402	R ¹ / ₈	G ¹ / ₈	8,0	18,5	42,0	10	100
40403	R ¹ / ₄	G ¹ / ₄	11,0	23,5	51,0	13	50
40404	R ³ / ₈	G ³ / ₈	11,5	26,0	56,0	17	25
40405	R ¹ / ₂	G ¹ / ₂	14,0	31,0	67,0	21	25
40406	R ³ / ₄	G ³ / ₄	16,0	33,0	73,0	25	10
40407	R1	G1	19,0	39,0	90,0	30	10

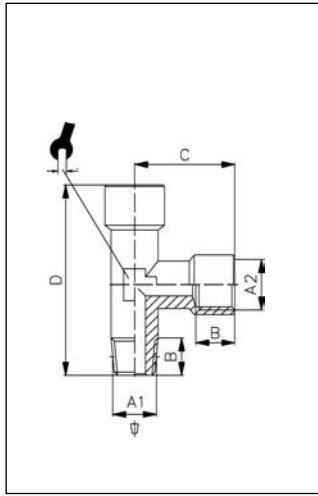

113

L-Stück konisch

Off-set male T-MFF

T-M.F.F.

Té conique inégal M.F.F.

	A1	A2	B	C	D		
40502	R ¹ / ₈	G ¹ / ₈	8,0	21,0	39,5	10	100
40503	R ¹ / ₄	G ¹ / ₄	11,0	23,5	49,0	13	50
40504	R ³ / ₈	G ³ / ₈	11,5	28,0	54,0	17	25
40505	R ¹ / ₂	G ¹ / ₂	14,0	33,5	64,5	21	25
40506	R ³ / ₄	G ³ / ₄	16,5	36,5	69,5	25	10
40507	R1	G1	19,0	45,0	84,0	30	10

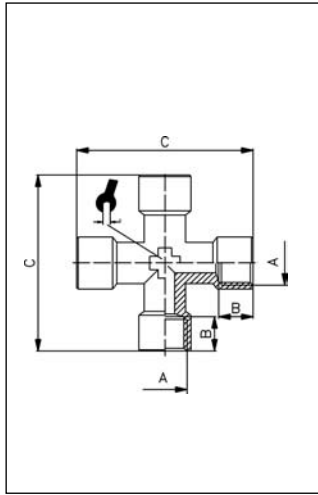

114

Kreuzstück

Female cross

Croce F.F.F.F.

Croix égale F.F.F.F.

	A	B	D		
60202	G ¹ / ₈	8,0	42	10	25
60203	G ¹ / ₄	11,0	51	13	25
60204	G ³ / ₈	11,5	56	17	25
60205	G ¹ / ₂	14,0	67	21	25

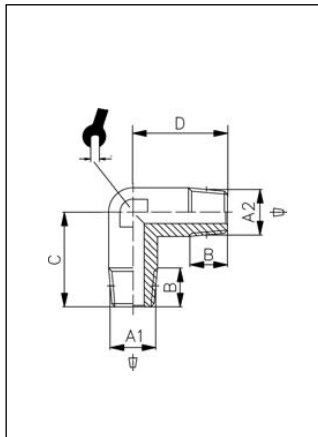

115

Winkelstück konisch

Male elbow

Elle M.M.

Équerre conique M.M.

	A1	A2	B	C	D		
50002	R ¹ / ₈	R ¹ / ₈	8,0	18,5	18,5	10	100
50008	R ¹ / ₄	R ¹ / ₈	11,0	21,5	19,0	10	100
50003	R ¹ / ₄	R ¹ / ₄	11,0	23,5	23,5	13	50
50004	R ³ / ₈	R ³ / ₈	11,5	26,0	26,0	17	25
50005	R ¹ / ₂	R ¹ / ₂	14,0	31,0	31,0	21	25
50006	R ³ / ₄	R ³ / ₄	16,0	33,0	33,0	25	10
50007	R1	R1	16,8	39,0	39,0	30	10

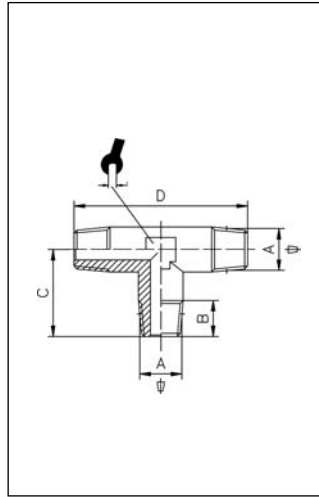

116

T-Stück konisch

Male Tee

T.M.M.M.

Té conique égal M.M.M.

	A	B	C	D		
40103	R ¹ / ₈	8,0	21,0	37,0	10	100
40104	R ¹ / ₄	11,0	25,5	47,0	13	50
40105	R ³ / ₈	11,5	28,0	52,0	17	25
40106	R ¹ / ₂	14,0	33,5	62,0	21	25
40107	R ³ / ₄	16,2	36,5	66,4	25	10
40108	R1	16,8	45,0	78,0	30	10

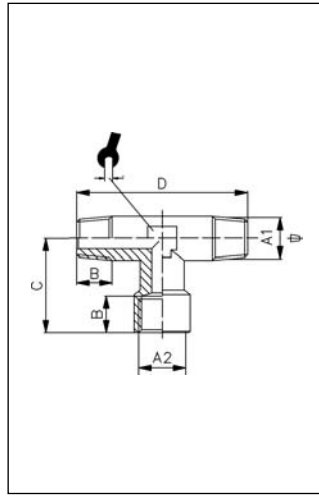

117

T-Stück konisch mit Außen-Innengewinde

Centre female tee

T.-M.F.M

Té conique inégal M.F.M.

	A1	A2	B	C	D		
40202	R ¹ / ₈	G ¹ / ₈	8,0	21,0	37,0	10	100
40203	R ¹ / ₄	G ¹ / ₄	11,0	25,5	47,0	13	50
40204	R ³ / ₈	G ³ / ₈	11,5	28,0	52,0	17	25
40205	R ¹ / ₂	G ¹ / ₂	14,0	33,5	62,0	21	25
40206	R ³ / ₄	G ³ / ₄	16,2	36,5	66,4	25	10
40207	R1	G1	16,8	45,0	78,0	30	10

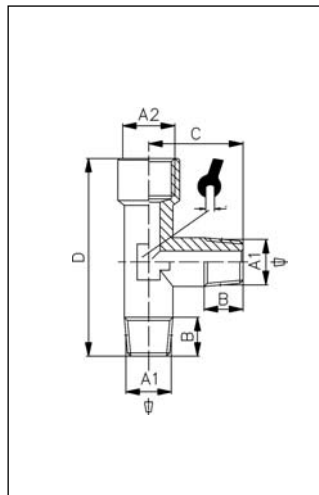

118

L-Stück konisch

Off-set female tee

T.-M.M.F.

Té conique inégal M.M.F.

	A1	A2	B	C	D		
40302	R ¹ / ₈	G ¹ / ₈	8,0	18,5	39,5	10	100
40303	R ¹ / ₄	G ¹ / ₄	11,0	23,5	49,0	13	50
40304	R ³ / ₈	G ³ / ₈	11,5	26,0	54,0	17	25
40305	R ¹ / ₂	G ¹ / ₂	14,0	31,0	64,5	21	25
40306	R ³ / ₄	G ³ / ₄	16,0	33,0	69,5	25	10
40307	R1	G1	16,8	39,0	84,0	30	10

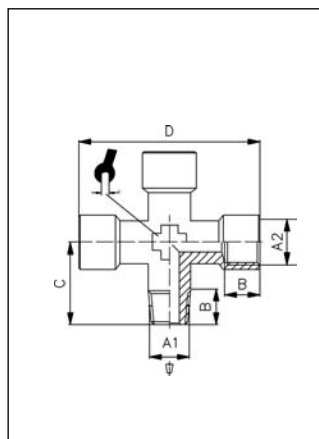

120

Kreuzstück konisch

1 male 3 female cross

Croce M.-F.F.F.M.

Croix conique inégale F.F.F.M.

	A1	A2	B	C	D		
60251	R ¹ / ₈	G ¹ / ₈	8,0	18,5	42	10	25
60252	R ¹ / ₄	G ¹ / ₄	11,0	23,5	49	13	25
60253	R ³ / ₈	G ³ / ₈	11,5	26,0	54	17	25
60254	R ¹ / ₂	G ¹ / ₂	14,0	31,0	67	21	25

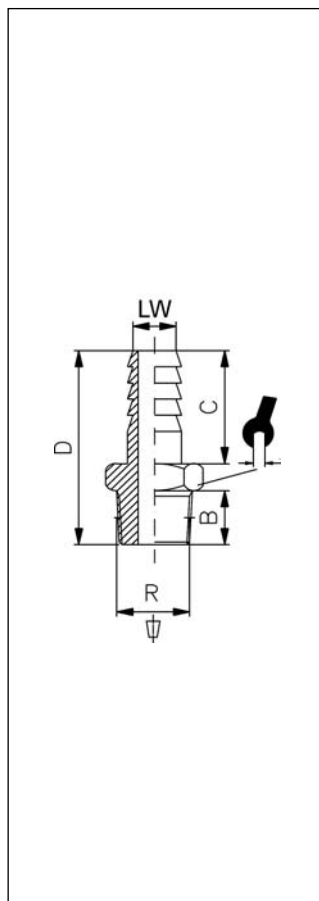

119

Schlauchtülle konisch

Male hose adapter

Portagomma maschio

Cannule conique mâle

	LW	R	B	C	D		
30402	6	R ¹ / ₈	7,5	19,5	32,0	12	100
30403	6	R ¹ / ₄	11,0	19,5	35,5	14	100
30404	7	R ¹ / ₈	7,5	19,5	32,0	12	100
30405	7	R ¹ / ₄	11,0	19,5	35,5	14	100
30406	87	R ¹ / ₈	7,5	19,5	32,0	12	100
30407	8	R ¹ / ₄	11,0	19,5	32,5	14	100
30408	9	R ¹ / ₈	7,5	19,5	32,0	12	100
30409	9	R ¹ / ₄	11,0	19,5	35,5	14	100
30410	9	R ³ / ₈	11,5	19,5	36,0	17	100
30411	9	R ¹ / ₂	14,0	19,5	39,0	22	100
30412	10	R ¹ / ₈	7,5	19,5	32,0	12	100
30413	10	R ¹ / ₄	11,0	19,5	35,5	14	100
30414	10	R ³ / ₈	11,5	19,5	36,0	17	100
30415	10	R ¹ / ₂	14,0	19,5	39,0	22	100
30416	12	R ¹ / ₄	11,0	19,5	35,5	14	50
30417	12	R ³ / ₈	11,5	19,5	36,0	17	50
30418	12	R ¹ / ₂	14,0	19,5	39,0	22	50
30419	14	R ³ / ₈	11,5	19,5	36,0	17	50
30420	16	R ³ / ₈	11,5	19,5	36,0	17	50
30421	14	R ¹ / ₂	14,0	19,5	39,0	22	50
30422	16	R ¹ / ₂	14,0	19,5	39,0	22	50
30426	17	R ¹ / ₂	14,0	19,5	39,0	22	50
30427	18	R ¹ / ₂	14,0	19,5	39,0	22	50

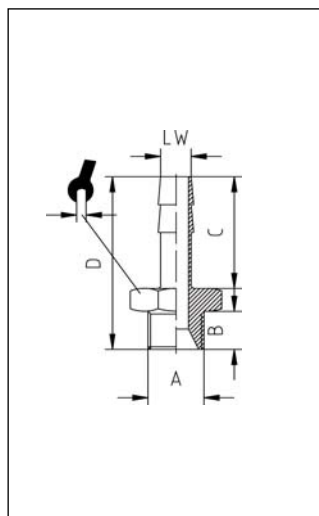

119/z

Schlauchtülle zylindrisch

Male hose adapter

Portagomma maschio

Cannule cylindrique mâle

	LW	A	B	C	D		
30454	7	G ¹ / ₈	20	6	30	12	100
30455	7	G ¹ / ₄	20	8	33	14	100
30456	8	G ¹ / ₈	20	6	30	12	100
30457	12	G ³ / ₈	20	9	34	19	100
30458	12	G ¹ / ₂	22	10	37,5	22	100
30459	9	G ¹ / ₄	20	8	33	14	100
30460	9	G ¹ / ₈	20	6	30	12	100
30462	9	G ³ / ₈	20	9	34	19	100
30461	12	G ¹ / ₄	20	8	33	14	50

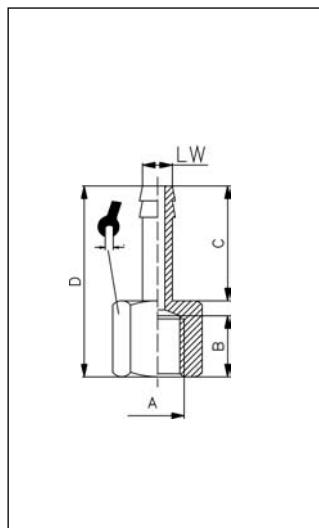

122

Schlauchtülle mit Innengewinde

Female hose adapter

Portagomma femmina

Cannule femelle

	LW	A	B	C	D		
30502	6	G ¹ / ₈	7,5	19,5	29,5	14	100
30503	7	G ¹ / ₈	7,5	19,5	29,5	14	100
33013	7	G ¹ / ₄	11,0	19,5	32,0	17	100
30504	8	G ¹ / ₄	11,0	19,5	32,0	17	100
30505	9	G ¹ / ₄	11,0	19,5	32,0	17	100
30507	10	G ³ / ₈	11,5	19,5	33,0	20	100
30510	12	G ³ / ₈	11,5	19,5	34,0	20	100
30511	12	G ¹ / ₂	15,0	19,5	38,0	24	100

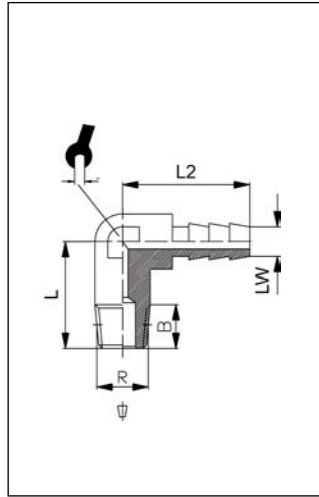

121

Winkeleinschraub mit Schlauchaufnahme

Elbow connector for tubes

Raccordo a gomito con portagomma

Raccord condor pour tubes

	R	LW	B	L	L1		
51000	R ¹ / ₈	6	8	18,5	21,5	9	100
51001	R ¹ / ₈	9	8	20,0	24,0	11	100
51002	R ¹ / ₄	6	11	22,0	22,5	10	100
51003	R ¹ / ₄	8	11	22,0	22,5	10	100
51004	R ¹ / ₄	9	11	22,0	24,0	11	100

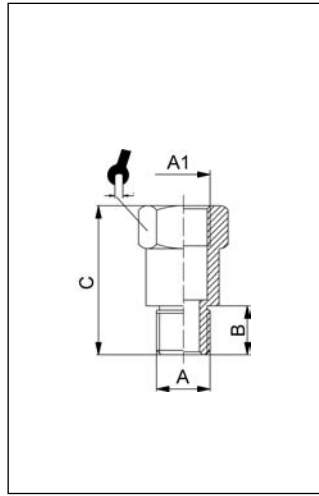

123

Verlängerung Innen-Außen zylindrisch

Extension-parallel

Prolunga-cilindrica

Prolongateur cylindrique

	A	A1	B	C		
20702	G ¹ / ₈	G ¹ / ₈	6	4,5	15	25
20703	G ¹ / ₈	G ¹ / ₈	6	5,5	20	25
20704	G ¹ / ₄	G ¹ / ₄	8	5,5	25	25
20705	G ¹ / ₄	G ¹ / ₄	8	5,5	33	25

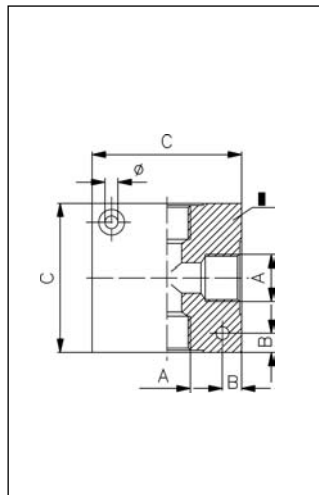

124

Verteilerblock aus Aluminium

Aluminium cross manifold

Ripartitore a croce in alluminio

Carré de distribution en aluminium

	A	B	C	ϕ		
60402	G ¹ / ₈	4	25	4,5	15	25
60403	G ¹ / ₈	7	40	5,5	20	25
60404	G ³ / ₈	8	50	,5	25	25
60405	G ¹ / ₂	8	50	5,5	33	25

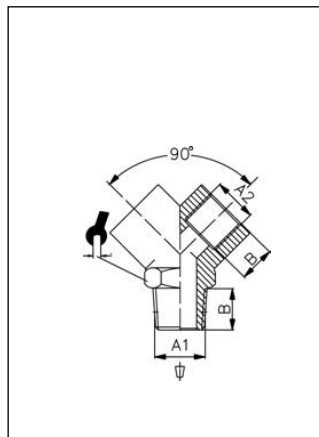

125

Y-Verteiler konisch

Male - Y connector con.

Raccordo a Y - conico

Raccord a Y conique

	A1	A2	B		
60002	R ¹ / ₈	G ¹ / ₈	8,0	14	50
60003	R ¹ / ₄	G ¹ / ₄	11,0	17	50
60004	R ³ / ₈	G ³ / ₈	11,5	22	25
60005	R ¹ / ₂	G ¹ / ₂	14,0	26	25

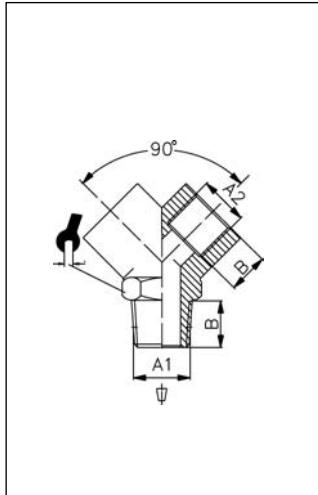

126

Y-Verteiler

Female Y

Y -Femmina

Y femelle F.F.F.



	A	B		
60102	G ¹ / ₈	8,0	14	50
60103	G ¹ / ₄	11,0	17	50
60104	G ³ / ₈	11,5	22	25
60105	G ¹ / ₂	14,0	26	25

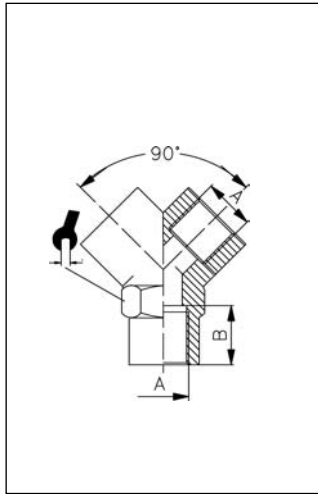

127

Schottverschraubung

Female bulkhead

Passaparete femmina

Traversée de cloison femelle



	G	A	B	C			
30601	M5	M10x1	10,5	14,0	14	14	100
30602	G ¹ / ₈	M16x1,5	14,0	18,0	22	19	100
30603	G ¹ / ₄	M20x1,5	21,0	25,0	27	24	100
30604	G ³ / ₈	M26x1,5	21,0	26,0	32	30	50
30605	G ¹ / ₂	M28x1,5	27,0	33,0	36	32	25

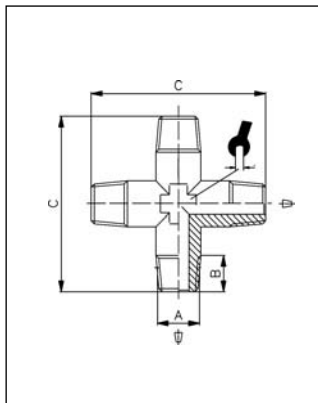

128

Kreuzstück konisch

Male cross

Croce M.M. M. M.

Croix conique égal M.M.M.M.



	A	B	C		
60302	R ¹ / ₈	8,0	34	10	25
60303	R ¹ / ₄	11,0	48	13	25
60304	R ³ / ₈	11,5	54	17	25
60305	R ¹ / ₂	14,0	59	21	25

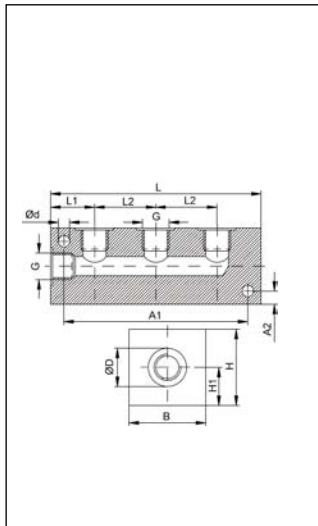

129

Verteilerleiste 3-fach

3-connection-block

Blocco a 3-connessione

Bloque 3 connections



	G	ØD	H	B	L	L1	L2	
12900	M5	8,5	15	15	40	10,0	10	10
12901	G ¹ / ₈	14,5	20	20	56	13,5	17	10
1290	G ¹ / ₄	19,0	30	30	89	20,0	29	5
12903	G ³ / ₈	23,0	40	30	85	20,0	26	5
12904	G ¹ / ₂	27,5	40	30	105	20,0	32	1
	H1	A1	ØD					
12900	10	32	3,4					
12901	12	46	4,4					
12902	17	74	6,4					
12903	19	72	6,4					
12904	22	90	6,4					

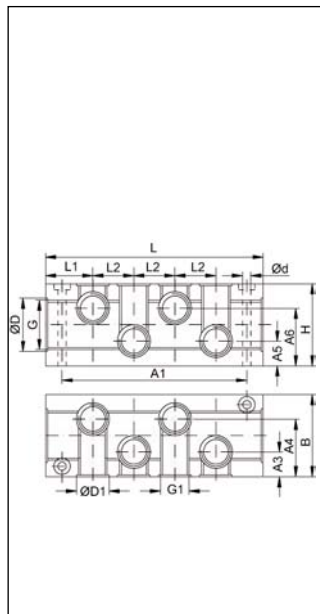

130

Verteilerleiste 8-fach

8-connection-block

Blocco a 8-connessione

Bloque 8 connections Verteilerleiste

	G	ØD	G1	ØD1	B	H	L	L1	■
60311	G ¹ / ₄	19,0	M5	8,5	32	25	65	17,5	10
60312	G ³ / ₈	23,0	G ¹ / ₈	14,5	40	30	114	22,5	5
60313	G ¹ / ₂	27,5	G ¹ / ₄	19,0	50	35	144	28,5	1
60314	G ³ / ₄	34,0	G ¹ / ₂	27,5	60	45	170	31,0	1

	L2	A1	A3	A4	A5	A6	Ød
60311	10	50	12,5	19,5	8,5	16,5	4,4
60312	23	100	16,5	24,5	10,5	19,5	6,5
60313	29	128	20,5	29,5	13,0	22,0	6,5
60314	36	150	27,0	33,0	19,5	25,5	8,5

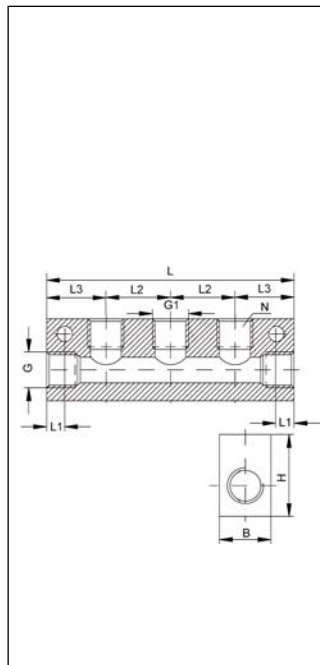

131

Durchgangleiste

Through - going block

Blocco - passante

Bloque passant

	G	G1	B	H	L1	L2	L3	L	N	■
60411	G ¹ / ₄	G ¹ / ₈	20	30	4,5	18	18	54	2	10
60412	G ¹ / ₄	G ¹ / ₈	20	30	4,5	18	18	72	3	10
60413	G ¹ / ₄	G ¹ / ₈	20	30	4,5	18	18	90	4	10
60414	G ¹ / ₄	G ¹ / ₈	20	30	4,5	18	18	108	5	5
60415	G ³ / ₈	G ¹ / ₄	25	40	8,5	24	22	68	2	5
60416	G ³ / ₈	G ¹ / ₄	25	40	8,5	24	22	92	3	5
60417	G ³ / ₈	G ¹ / ₄	25	40	8,5	24	22	116	4	5
60418	G ³ / ₈	G ¹ / ₄	25	40	8,5	24	22	140	5	5

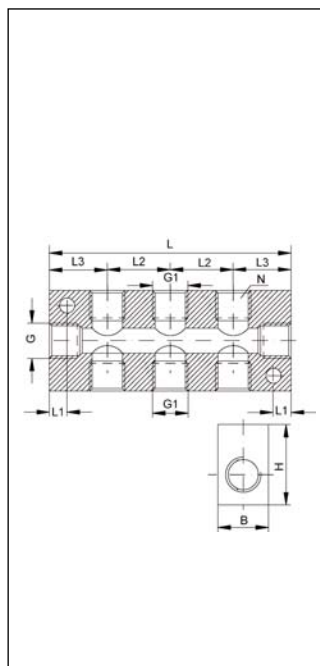

132

Durchgangleiste

Through - going block

Blocco - passante

Bloque passant

	G	G1	B	H	L1	L2	L3	L	N	■
60411	G ¹ / ₄	G ¹ / ₈	20	30	4,5	18	18	54	2+2	10
60412	G ¹ / ₄	G ¹ / ₈	20	30	4,5	18	18	72	3+3	10
60413	G ¹ / ₄	G ¹ / ₈	20	30	4,5	18	18	90	4+4	10
60414	G ¹ / ₄	G ¹ / ₈	20	30	4,5	18	18	108	5+5	5
60415	G ³ / ₈	G ¹ / ₄	25	40	8,5	24	22	68	2+2	5
60416	G ³ / ₈	G ¹ / ₄	25	40	8,5	24	22	92	3+3	5
60417	G ³ / ₈	G ¹ / ₄	25	40	8,5	24	22	116	4+4	5
60418	G ³ / ₈	G ¹ / ₄	25	40	8,5	24	22	140	5+5	5

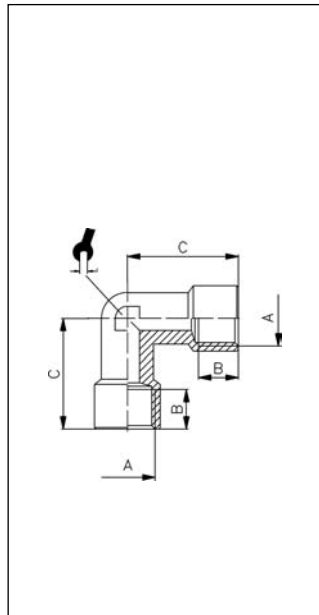

109 blank

Winkelstück

Femelle Elbow

Elle F.F

Équerre femelle femelle

	A	B	C		
R50102	G ¹ / ₈	8,0	21,0	10	100
R50103	G ¹ / ₄	11,0	25,5	13	50
R50104	G ³ / ₈	11,5	28,0	17	25
R50105	G ¹ / ₂	14,0	33,5	21	25
R50106	G ³ / ₄	16,5	36,5	25	10
R50107	G1	19,0	45,0	30	10

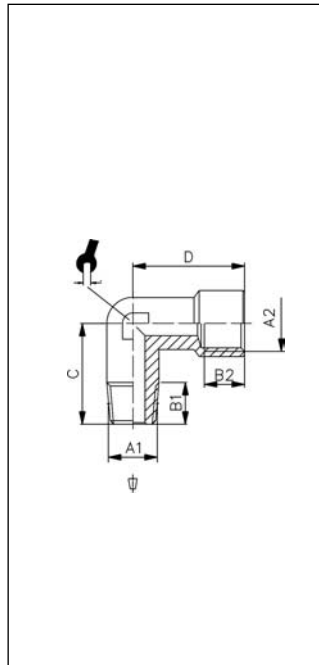

110 blank

Winkelstück

Male-female elbow

L-M/F

Équerre conique M/F

	A1	A2	B1	B2	C	D		
R50202	R ¹ / ₈	G ¹ / ₈	8,0	8,0	18,5	21,0	10	100
R50203	R ¹ / ₄	G ¹ / ₄	11,0	11,0	23,5	25,5	13	50
R50204	R ³ / ₈	G ³ / ₈	11,5	11,5	26,0	28,0	17	25
R50205	R ¹ / ₂	G ¹ / ₂	14,0	14,0	31,0	33,5	21	25
R50206	R ³ / ₄	G ³ / ₄	16,0	16,0	33,0	36,5	25	10
R50207	R1	G1	19,0	19,0	39,0	45,0	30	10

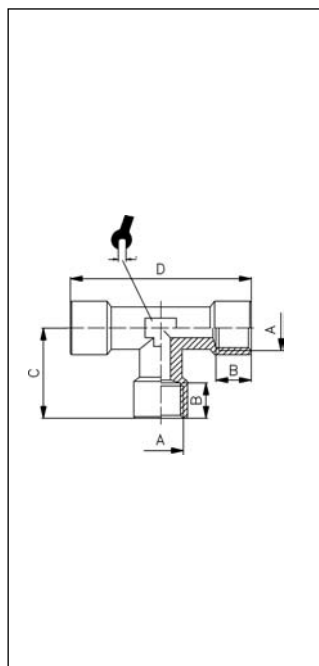

111 blank

T-Stück

Female Tee

T-F.F.F.

Té égal F.F.F.

	A	B	C	D		
R40003	G ¹ / ₈	8,0	21,0	42,0	10	100
R40004	G ¹ / ₄	11,0	25,5	51,0	13	50
R40005	G ³ / ₈	11,5	28,0	56,0	17	25
R40006	G ¹ / ₂	14,0	33,5	67,0	21	25
R40007	G ³ / ₄	16,0	36,5	73,0	25	10
R40008	G1	19,0	45,0	90,0	30	10

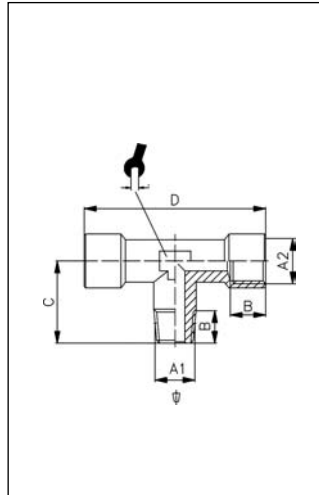

112 blank

T-Stück konisch

Centre male Tee

T-F. M.F.

Té conique inégal F.F.M.

	A1	A2	B	C	D		
R40402	R ¹ / ₈	G ¹ / ₈	8,0	18,5	42,0	10	100
R40403	R ¹ / ₄	G ¹ / ₄	11,0	23,5	51,0	13	50
R40404	R ³ / ₈	G ³ / ₈	11,5	26,0	56,0	17	25
R40405	R ¹ / ₂	G ¹ / ₂	14,0	31,0	67,0	21	25
R40406	R ³ / ₄	G ³ / ₄	16,0	33,0	73,0	25	10
R40407	R1	G1	19,0	39,0	90,0	30	10

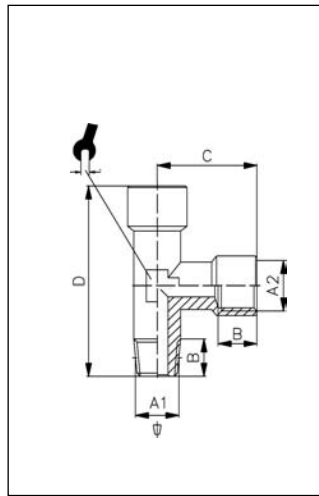

113 blank

L-Stück konisch

Off-set male T-MFF

T-M.F.F.

Té conique inégal M.F.F.

	A1	A2	B	C	D		
R40502	R ¹ / ₈	G ¹ / ₈	8,0	21,0	39,5	10	100
R40503	R ¹ / ₄	G ¹ / ₄	11,0	23,5	49,0	13	50
R40504	R ³ / ₈	G ³ / ₈	11,5	28,0	54,0	17	25
R40505	R ¹ / ₂	G ¹ / ₂	14,0	33,5	64,5	21	25
R40506	R ³ / ₄	G ³ / ₄	16,5	36,5	69,5	25	10
R40507	R1	G1	19,0	45,0	84,0	30	10

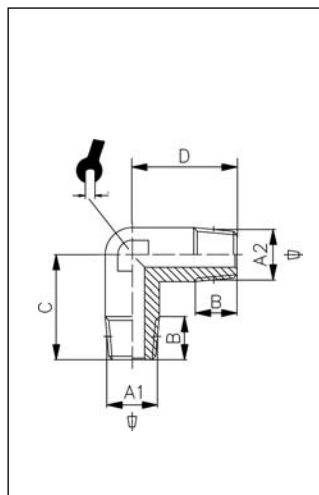

115 blank

Winkelstück konisch

Male elbow

Elle M.M.

Équerre conique M.M.

	A1	A2	B1	B2	C	D		
40402	R ¹ / ₈	R ¹ / ₈	8,0	8,0	18,5	18,5	10	100
40403	R ¹ / ₄	R ¹ / ₄	11,0	11,0	23,5	23,5	13	50
40404	R ³ / ₈	R ³ / ₈	11,5	11,5	26,0	26,0	17	25
40405	R ¹ / ₂	R ¹ / ₂	14,0	14,0	31,0	31,0	21	25
40406	R ³ / ₄	R ³ / ₄	16,0	16,0	33,0	33,0	25	10
40407	R1	R1	16,8	16,8	39,0	39,0	30	10

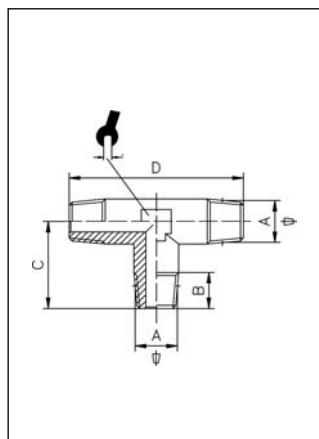

116 blank

T-Stück konisch

Male Tee

T.M.M.M.

Té conique égal M.M.M.

	A	B	C	D		
R40104	R ¹ / ₄	11,0	23,5	47,0	13	50
R40105	R ³ / ₈	11,5	26,0	52,0	17	25
R40106	R ¹ / ₂	14,0	31,0	62,0	21	25
R40107	R ³ / ₄	16,2	33,0	64,4	25	10
R40108	R1	16,8	39,0	78,0	30	10